

BUILDING

PRODUCTIVITY

**INTEGRATED
MEZZANINE SYSTEMS**

MiTek[®]



MiTek®

MEZZANINE EXPERTISE YOU CAN RELY ON



With a reputation for quality, speed and reliability, MiTek is a leading mezzanine floor supplier and part of the global MiTek® group. We have operations in the UK, Europe and North America, where our experts are ready to design, make and build a bespoke steel support structure to meet the evolving needs of your business.

From straightforward floors to the most complex projects, our custom-engineered mezzanine structures secure competitive advantage by optimising space utilisation and boosting productivity.

We partner with warehouse developers, general contractors, system integrators and end users

worldwide. Our turnkey mezzanine solutions are relied upon in diverse industrial, distribution, manufacturing and commercial environments, where they integrate seamlessly with automation. From e-commerce warehouses to automotive showrooms, MiTek's steel platforms enable businesses to thrive and grow.

/// A special thank you to your team who carried out our project with great commitment and flexibility. It is always a pleasure to work with experienced and trustworthy partners. ///

Andreas Weller, Site Manager, **Dematic**



REASONS TO PARTNER WITH MITEK

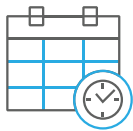

Experience – we've been designing, manufacturing and installing mezzanine solutions for nearly 40 years, so we offer our clients experience from over 20,000 projects worldwide.



Tailored, future-proof designs – our team will create a unique solution with the optimum balance of strength, cost-effectiveness and sustainability to meet your business needs today and tomorrow.



Accreditation – we are ISO 9001, ISO 14001, ISO 45001 and EN1090 certified and offer a full CE-marking Execution Class 2-accredited supply chain. We also hold industry-recognised SMAS, CHAS and Safe Contractor safety accreditations.



Sustainability – our steel and timber floors have a lower carbon footprint than concrete systems, and we further reduce carbon by selecting local supply chain partners.



In-house expertise – we have the design, engineering and project management skills in house to deliver your project, on time and within budget.



Seamless integration – experienced in working with 8 of the world's top 10 system integrators and investing heavily in R&D, we deliver mezzanine solutions that integrate seamlessly with robotic and automated systems.



Low risk – full design, installation and safety compliance to UK and EU regulations means lower risk of costs and delays. Plus, partnering with a Berkshire Hathaway company means you benefit from reduced commercial risk.



Global scale – as the first global mezzanine provider, we deliver large-scale projects rapidly and to a consistent standard across borders, backed up by a unified service network.

Early advice pays off

Send us an email: mezzanine-uk@mii.com or call us on 01732 849 900



A COMPREHENSIVE SERVICE: DESIGN – MAKE – BUILD

Design

Our priority during the design phase is open communication, which ensures effective collaboration to achieve the optimum mezzanine solution. Our experienced, in-house design team combines industry-leading technology that is integrated to BMI standards – including AutoCAD, Tekla, IDEA StatiCA and Dlubal – with proprietary software to create a comprehensively engineered mezzanine system. Our structural engineers can provide technical advice on all aspects of your plans, including integration with any technology. We deliver fully compliant mezzanine solutions for both new and existing facilities that meet all building, safety and fire regulations.

Make

In line with our philosophy of *Global Partnerships, Local Solutions*, we are committed to local sourcing in our procurement strategy in order to minimise the carbon footprint associated with your mezzanine project. By outsourcing the fabrication of our solutions to our network of long-standing and reliable partners – who are continuously vetted for quality and sustainability – we ensure that we always have the capacity for multiple projects, thereby avoiding delays for our customers. We are proud to offer a full CE-marking Execution Class 2-accredited supply chain.

Build

Every MiTek solution has a dedicated project manager, providing a single point of contact and giving you peace of mind that your project will run smoothly, remain on schedule and keep within budget. Our SHEQ processes are unrivalled in the mezzanine industry, with our zero-tolerance approach to health and safety helping to protect everyone associated with your project. In order to ensure minimal disruption, our team can work around your operational needs and collaborate with other suppliers as required to achieve an optimally phased programme of work on site.



YOUR SPECIALIST FOR LARGE AND INTEGRATED PROJECTS

Although mezzanine floors appear to be relatively simple constructions, their planning and installation is becoming increasingly complex. Automation, digitalisation and robotics bring special requirements in terms of mezzanine construction in both the production and distribution sectors.

MiTek is your experienced partner when it comes to the realisation of large-scale projects and integration with automated technologies. We bring extensive know-how and the capacity you need for complex and high-performance installations, including detailed knowledge of country-specific building regulations.

Our White Paper entitled 'Expert insight into planning a large or integrated mezzanine floor solution' is available as a free download at www.mitek-mezzanine.com.



/// It was very important that MiTek had integration experience, as the customer needed products to be moved swiftly and efficiently between mezzanine levels. ///

Steve Hicks, Managing Director Contract Logistics, **Noatum**



THE RIGHT DESIGN FOR EVERY APPLICATION

We offer various construction technologies for our steel mezzanine systems and will always offer you the most suitable option for your specific requirements.

For a lightweight application, a cold-formed design can save costs, as it requires less material. However, where large beam spans or high load capacities are needed, a hybrid solution could be the preferred and more cost-effective option. Our Mezzanine7 product is the ultimate solution for future-proofing your structure. Any combination of these designs – in some cases, all three – may be used in a single project. Our expert team is on hand to give you advice and provide the best solution for your needs.

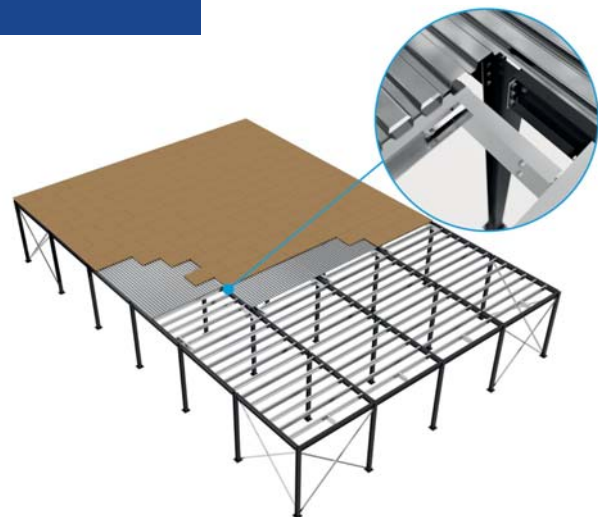

Mezzanine7

Constructed from hot-rolled primary beams, cold-formed joists and a composite flooring system, Mezzanine7 is the ultimate solution for strength and future-proofing.

- Composite floor incorporating B-Deck plus top decking layer
- Point load capacity up to 5000kg, depending on final top decking layer
- Future-proofed for upgrades and relocation of heavy point loads
- Compatible with most robotics and AGVs
- Reduced deflection and vibration
- Increased light reflectivity
- Class '0' fire resistance

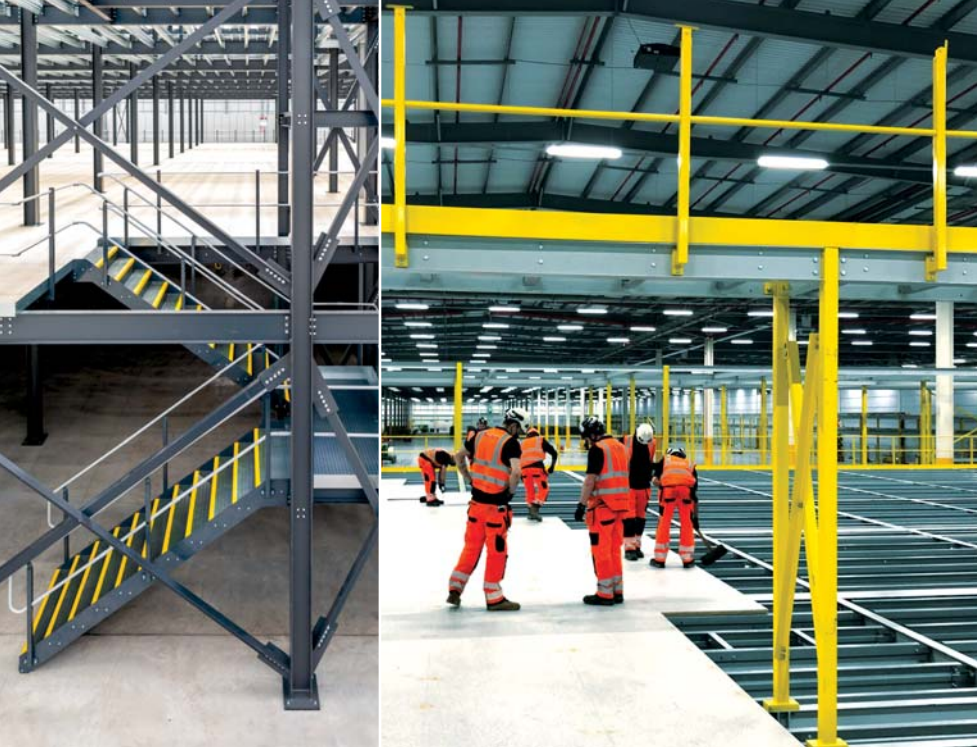

INVESTING IN
A FORWARD-
THINKING
SOLUTION WILL
SAVE YOU MONEY
IN THE LONG RUN.

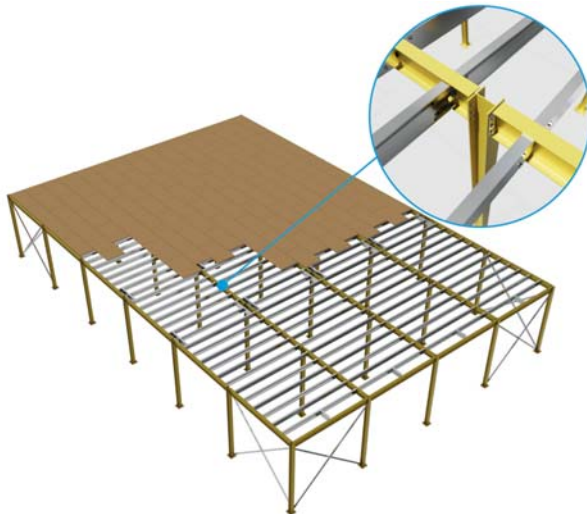

Hybrid mezzanine

Designed for heavier applications, hybrid steel mezzanines are constructed from hot-rolled primary beams and cold-formed joists.

- Longer beam spans, higher load capacity & less deflection
- Unbraced design possible
- Fire protection (through intumescent paint)
- Heavier structure due to more robust hot-rolled parts

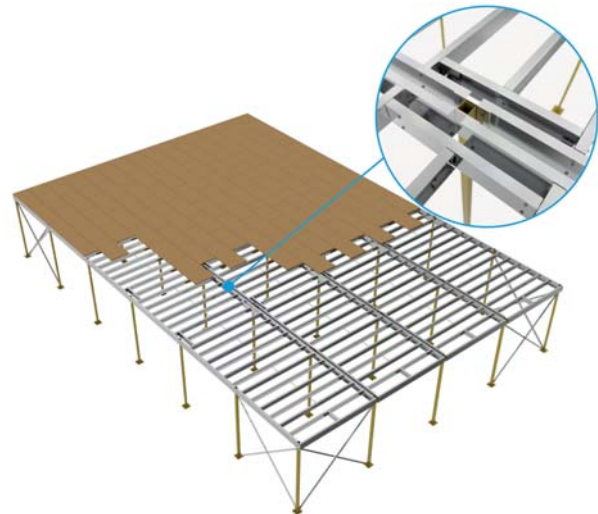

Cold-formed mezzanine

A steel platform for lightweight applications, this solution is constructed from cold-formed primary beams and cold-formed joists.

- Less embodied carbon due to lighter structure
- Faster lead-time
- Shorter installation period
- Some design limitations (beam span, load capacity & deflection)

“ One of the challenges we faced with this project was to install a mezzanine structure that would allow for future changes, especially to the racking positions. We were impressed by the Mezzanine7 solution, as its higher point load capacity provided our client with the required flexibility. ”

Jaap Vos, Managing Director, **SSI Schäfer**



WHO WE ARE

MiTek®, part of Berkshire Hathaway, is a global company focused on transforming the construction industry through creative solutions that meet the demand for smarter, more affordable and more sustainable buildings. We provide engineered products, integrated software, services and automated solutions for the building industry worldwide. Innovating and expanding into aspects of global building, MiTek empowers customers to improve the way they design, make and build.

Based in Europe and North America, our team of dedicated mezzanine specialists collaborate to design, manufacture and install innovative and future-proofed steel mezzanine systems for commercial and industrial applications. Our solutions secure competitive advantage by optimising space utilisation and boosting productivity. Customers include warehouse developers, general contractors, system integrators and end users in Europe and worldwide. With nearly 40 years' experience from more than 20,000 mezzanine projects, MiTek is your experienced partner when it comes to the integration of automated technologies and the realisation of large or complex mezzanine projects.

GET IN TOUCH – WE LOOK FORWARD TO HEARING FROM YOU.

United Kingdom

+44 (0) 1732 849900 | mezzanine-UK@mii.com

Germany

+49 (0) 221 8028 541 | mezzanine-EU@mii.com

North America

+1 262 789 1966 | mezzanine-NA@mii.com

A photograph of a large industrial building's interior, showing a complex steel mezzanine structure with multiple levels of beams and columns. The floor is a light-colored concrete. The lighting is bright, highlighting the metallic surfaces.

www.mitek-mezzanine.com